

MILLPWR^{G2}

2 or 3 Axes Control / 3 Axes Readout



**Powerful conversational
CNC retrofit system
for knee and bed mills**

ACU-RITE[®]
www.acu-rite.com

Boosting productivity is now "POWERFUL EASY"

Make the MILLPWR^{G2} your go-to choice for CNC retrofits.

Faster set-ups, shorter run times and a major boost in productivity are just one "powerful easy" retrofit away. The new ACU-RITE MILLPWR^{G2} control and retrofit kits can turn just about any knee mill into a powerhouse money-maker.

USB and Ethernet compatible, the new G2 features a bright 12.1" high resolution display, 1 GHz processor and plenty of programming capabilities – estimated runtimes, expanded tool/datum offsets, enhanced tool paths, a dxf converter – plus much, much more.

The MILLPWR^{G2} is a contouring control that enables you to program conventional machining operations right at the machine in an easy-to-use conversational programming language. It is designed for both knee mills and bed mills with up to 3 axes.

MILLPWR^{G2} was developed specifically for machinists where manual and automated operation are both useful and needed. It's designed to maximize throughput by significantly reducing set-up time, scrap, and other non-productive operations, thereby increasing your efficiency, productivity and profitability.

A closed-looped system with positioning feedback provided by ACU-RITE precision linear encoders (1µm/0.00005" resolution), MILLPWR^{G2} also includes Position-Trac™, an advanced, unique feature that enables you to easily, quickly and accurately re-establish work piece zero after shutting down, or power loss.



"The bright display and 3D graphics make it very easy to use. Production has increased due to the streamlined navigation and faster set-ups, thanks to user-friendly programming and expanded tool/datum offsets."
– John Reynolds, Plant Manager

MILLPWR^{G2} Retrofit Kit

**CNC system for knee mills
and bed mills.**



Kit Includes:

- Remote stop/go switch
- Ball screws
- (1um/0.00005" resolution) precision linear encoders
- Servo drives and motors
- Motor mounting castings and hardware
- Handwheels
- Console and encoder mounting hardware
- Machine specific bracketry

Plus the G2 CNC control itself.



Easy-to-master programming improves efficiency, profitability

Standardized menus make it easy to program common features like lines, arcs, custom pockets, bolt hole patterns, and islands. To add a feature to your program, simply press a function key and then follow the prompts. MILLPWR^{G2} also includes an “engrave” option for engraving alphanumeric characters vertically, horizontally, diagonally or along an arc.

Common machining features are now as simple as press and go.



TOOL - Program tools by diameter, length offset, type direction and speed



POSITION/DRILL - Drill, bore and position



RECTANGLES - Pocket, frame, face, and slot



LINES/DIAGONALS - Defined by from and to points or by angles



CIRCLES - Pocket, frame, ring and helix



ARCS - Defined by from and to points, or by sweep, center and 3-point arcs



HOLE PATTERNS - Bolt hole patterns; full & partial circles, linear row/column, rectangular frame and array



BLENDS - Insert a corner radius between two lines, two arcs, or a line and an arc



USB CONNECTIVITY - FRONT & BACK

Loading and off-loading programs, importing data via USB is now a plug-and-play convenience, with USB ports located on both the front and the back of the new G2 control.

MILLPWR^{G2} – Specifications

DRO Mode	
Multiple Datums (Fixture Offset)	99
Skew	Yes
Zero Reset	Yes
Near Zero Warning	Yes
PGM Mode	
Estimated Machining Time	Yes
Graphic View	2D Line / 3D Line / 3D Solid
Block Form	Yes, w/ User Override
Custom Pocket & Islands	Yes, Ramp Feed & Optimized Path
Replication (Repeat, Rotate, Mirror)	Yes
Engrave (Line / Arc)	Yes
Program Manager Navigation	Tree w/ Program Type Filter
Long Program Names	Yes
Program Preview	Listing & Graphic w/ Estimated Machining Time
Internal Storage	2.5 GB Flash (User)
Explode Step	Hole Patterns & Repeat / Rotate / Mirror
Reverse (Step / Path)	Yes
Shift Steps	Yes
Auto Save (Program)	Yes
Program Size Limit (MPT only)	9999 Steps
DXF File Import	Yes
G-code Program	Yes, w/ Graphics Support
On-Screen Help	User Manual Viewer (Text & Graphics)
Parts Counter & Clock	Yes
Manual / Auto Z Control	Yes, 3 Axes
Optional Stop (G-code Only)	Yes
Feed Override	Potentiometer
Error Compensation	Linear & Bidirectional Non-linear
Hardware	
Processor	1 GHz Celeron® M
Display	12.1" 1024 x 768 TFT LCD
Remote Pendant (Stop / Go)	Yes
Housing	Die Cast Metal (Bezel & Back)
Connections	Ethernet, USB (x2), RS-232

3D graphics system improves programming efficiency and accuracy

Programming cycles use a simple, easy-to-understand set of machinist language prompts, accompanied by content-specific “help” graphics. Here is a step-by-step look at the new G2 graphical interface, as a simple bolt hole circle and pocket are entered:

Intuitive navigation menus eliminate the need for multiple screens.

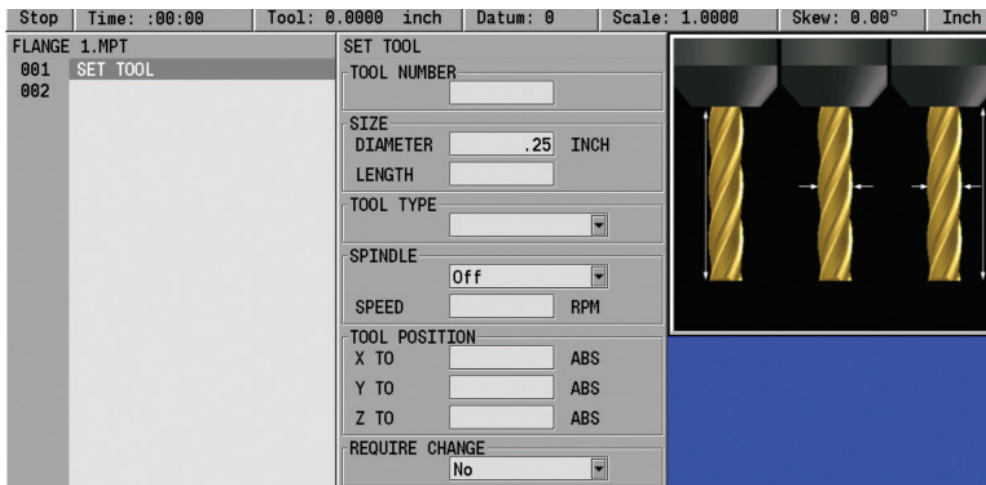

STEP 1 – All programs begin with the tool. Parameters are entered in the middle column and are graphically supported in the right column for each field.

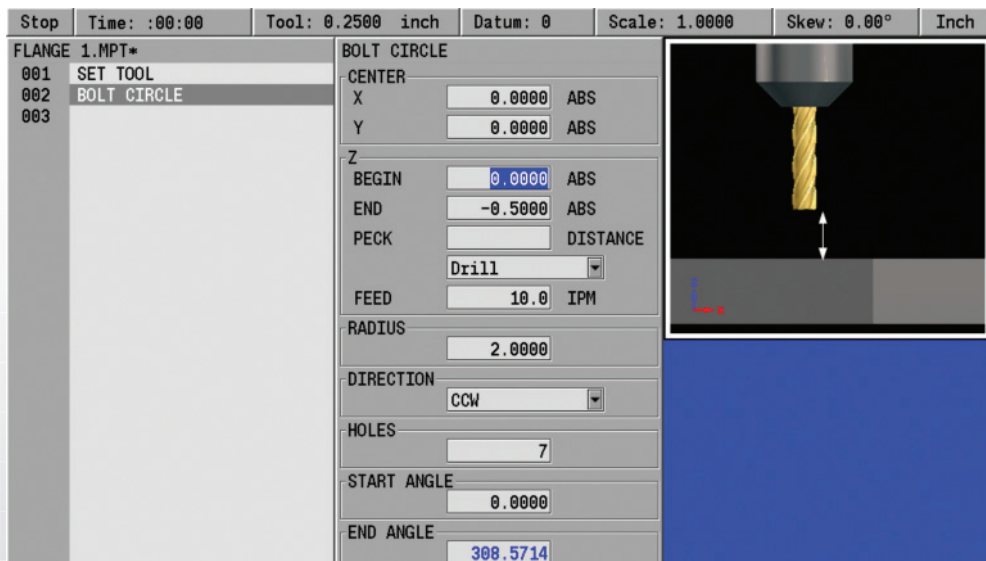

STEP 2 – Select a cycle to be created. In this case, a circular bolt hole pattern.

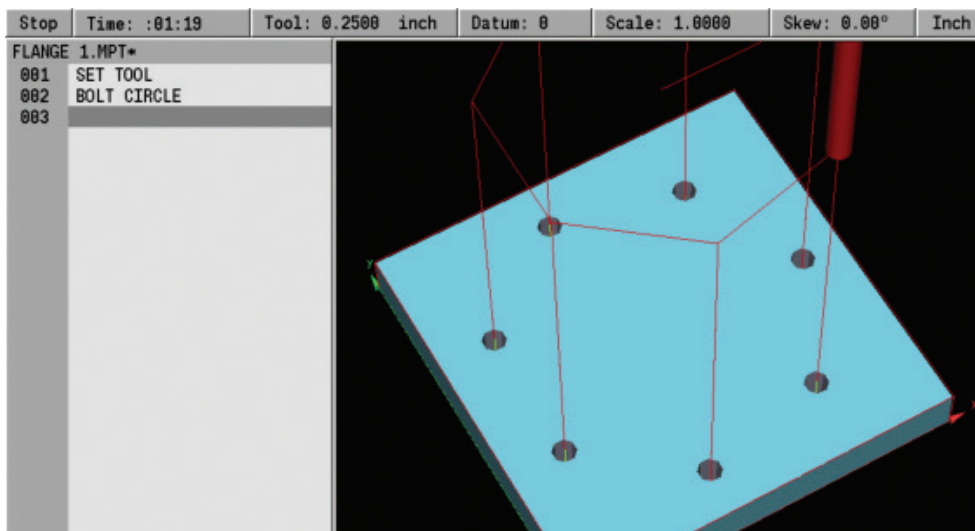

STEP 3 – Once the circular bolt hole pattern data has been entered into the form press the USE hard key and a graphic of the program is displayed.

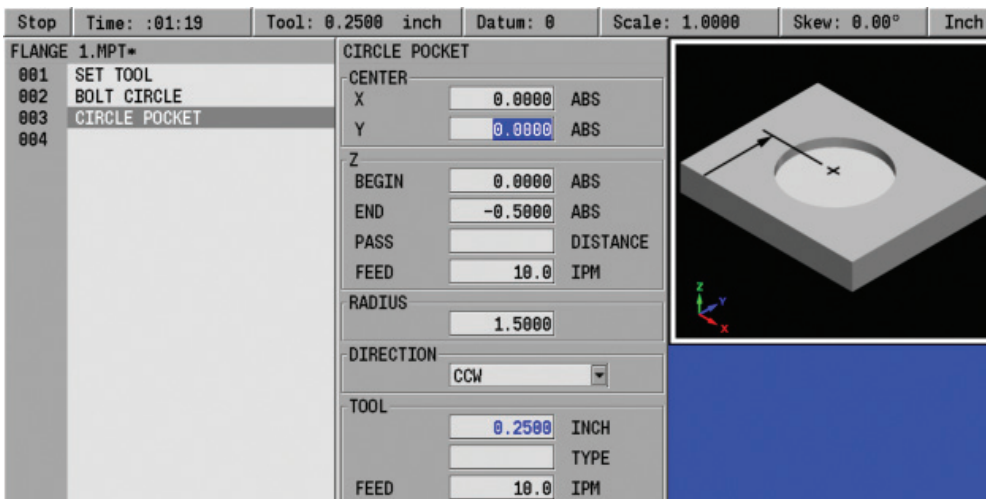

STEP 4 – Create a second cycle. Adding a circular pocket that is mapped in real time within the help graphic screen.

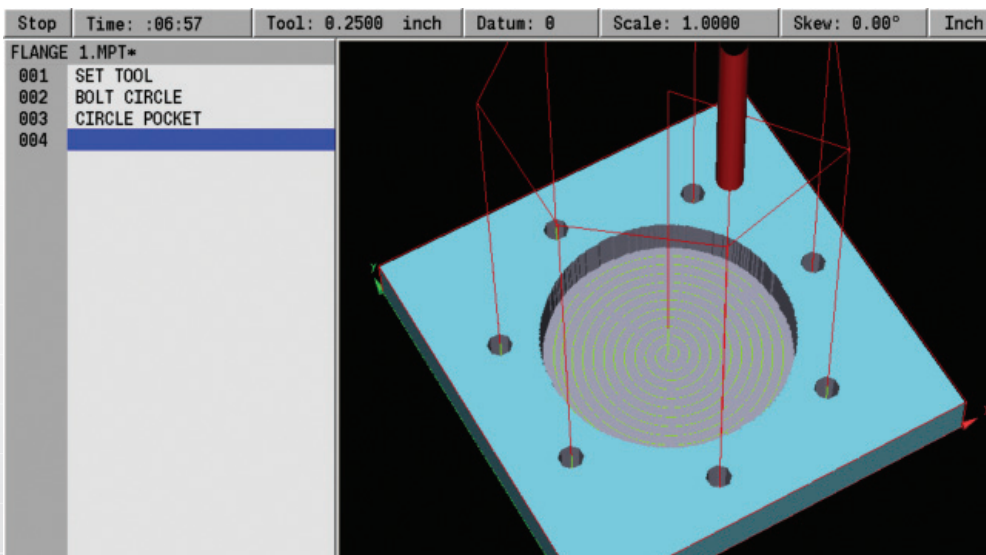

STEP 5 – Tool paths are also displayed in 3D graphics that can be rotated and manipulated. The program is ready to run. Simply press "GO."

Options

Offline Software

This allows you to create programs on a Windows compatible PC and permits those programs to be loaded into the MILLPWR^{G2} via USB or ethernet.

Upgrade

Upgrading from an old MILLPWR^{II} to MILLPWR^{G2} only requires the new G2 console and mounting arm.

Accessories

Knee Scale for Coupling Z (Quill) and W (Knee) G2

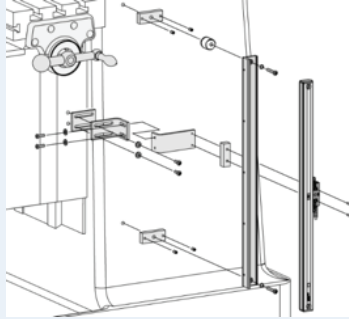

This option provides the machine operator positional feedback on the control when the knee is manual moved.

Electronic Edge Finder or Touch Probe



The stylus is deflected when it contacts the workpiece, and the edge finder sends a triggering signal over the connecting cable.

The edge finder allows you to set datums quickly and easily, without leaving marks on the workpiece.

MILLPWR^{G2} is backed by a comprehensive 2-year warranty and supported by a nationwide network of factory trained and certified distributors. Our distribution network is readily available to provide you with prompt delivery, product training and skilled technical service installation and support.

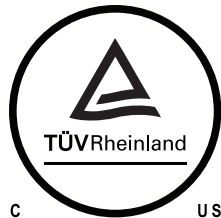

877-920-2703
www.acu-rite.com

ACU-RITE[®]

333 State Parkway | Schaumburg, IL 60173-5337